

S600 SERIES (Straight Dip Type)

SPECIFICATION

Insulator Material : PBT+30%GF UL94V-0
 Contact Material : Phosphor Bronze
 Plating : Selective Gold Plating Over Nickel On Contact Point
 100µ" Tin Plating On Tail Section
 50µ" Nickel Underplating
 Current Rating : 3 Ampere
 Insulation Resistance : 5000 megohms minimum
 Dielectric Withstanding Voltage : 1000 VAC RMS
 Operation Temperature Range : -55°C to +105°C
 Insertion Force (Max.) : 30 LBS
 Withdrawal Force (Min.) : 10 LBS

ORDERING INFORMATION

S600 - □□ - □ - 1

Terminal Style ↓

00 : Straight Dip Type

No. of Contacts

50
64

Insulator Style



1 : Rounded Edge

Plating

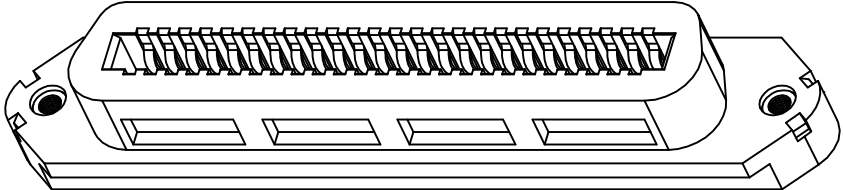
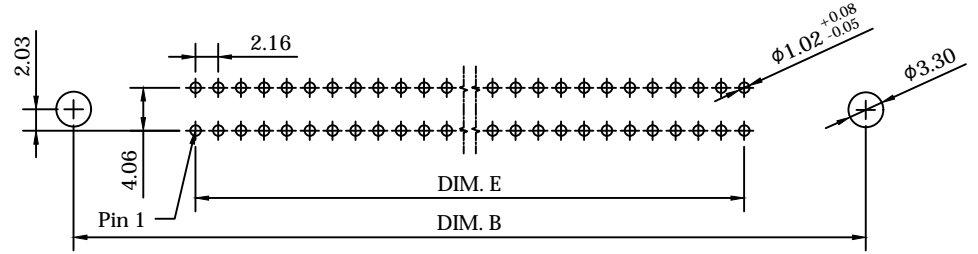
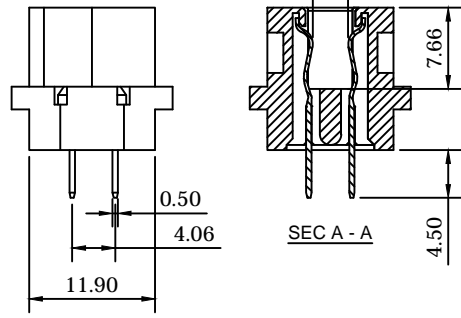
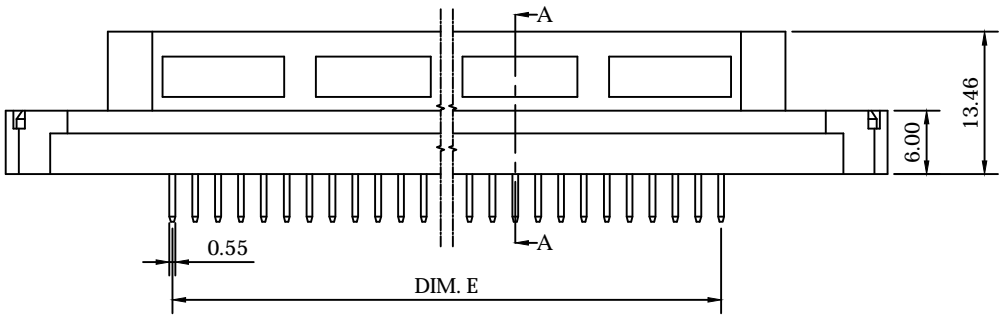
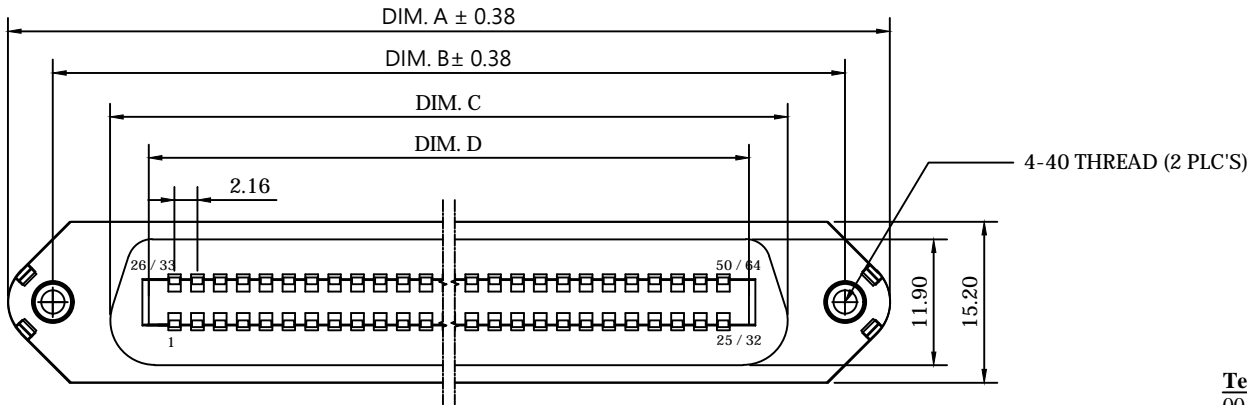
1 : 10µ" 4 : 5µ" 7 : Tin overall
 2 : G/F 5 : G/F overall 8 : 15µ"
 3 : 3µ" 6 : 30µ" 9 : 20µ"



No. of Contacts	Dimensions (Dim.)				
	A	B	C	D	E
25/50	83.31	74.83	64.02	56.70	51.84
32/64	98.43	89.95	79.14	71.82	66.96

Title : Customer Drawing	Type : Centronic Connector	 彩電企業股份有限公司 CHARTRON INCORPORATION
Part No. : S600 Series (Straight Dip Type)		
Description :		Tolerances Unless Otherwise Specified : X. ± 0.50 .X ± 0.38 .XX ± 0.25 X.° ± .X° ± .XX° ±
Pitch 2.16 mm Centronic Connector Female Straight Dip Type Row To Row 4.06 mm, Tail Length 4.50 mm Round Edge Type Insulator		
DWG No. : 010 - 0000 - S600-1	Date : 26 - Oct. - 2017	 Dim. Scale Sheet Rev. mm N/A 1 of 1 A
APPD. : James C.	CHK. : Connie Z.	